

A Picture to Remember



INSTALLATION INSTRUCTIONS

Carefully remove and unwrap all the contents of box. Referring to the parts list, make sure you have everything needed to proceed with the installation of the lens. If any parts are missing, contact PrismaSonic immediately.

Inspect the lens to make sure there are no shipping defects. If you notice a problem with the lens itself, or the lens' mechanical system, contact PrismaSonic immediately.

Parts list:

- Lens Unit
- Shipping Rail (2 pcs)
- Stand Plate
- Stand Rail (4 pcs)
- Stand Rail Extenders (4 pcs)
- Slide Lock (4 pcs)
- Power Cord
- Power Converter
- Remote Controller
- L-Wrench 3, mm
- L-Wrench 4, mm
- L-Wrench 5, mm
- Black Cap
- Skt Cap Screw, M6 x 10 (6 pcs)
- Instruction Manual

Bringing the lens into the use:

Flip the **lens unit** with **shipping rails** upside down on a table. By using the **L-wrench, 5 mm** carefully remove the delivery lock screw of large lens from the bottom plate (**Fig 1-a**). After this release the two upper screws of front element (**Fig 1-b**) by using the **L-wrench, 3mm**.

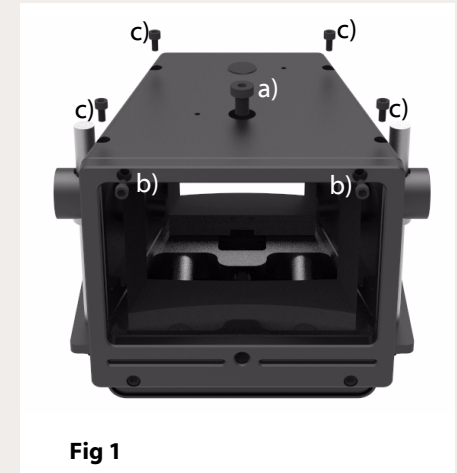

STEP 2

Remove the bottom plate (**Fig 2**) of housing by releasing the four screws on the bottom plate (**Fig 1-c**). Now carefully take off the plastic cover coats from both sides of both lenses. Remove also the cover coats from both IR windows of motor box.

STEP 3

Insert the bottom plate back to the housing and prepare to affix the four screws (**Fig 3-a**) with **L-wrench 3mm**. Tighten the screws securely. Also insert the **black cap** into the slot of bottom plate (**Fig 3-b**).

Now also attach the two cap screws of front plate back to their places (**Fig 3-c**).

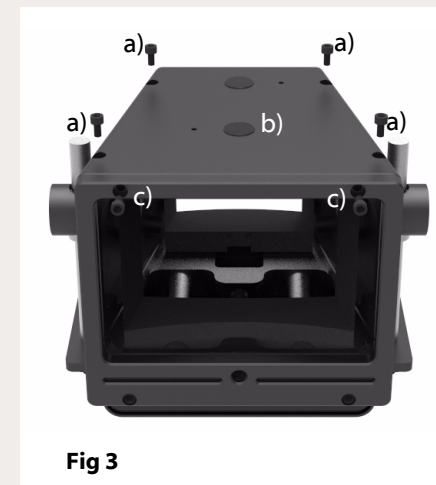

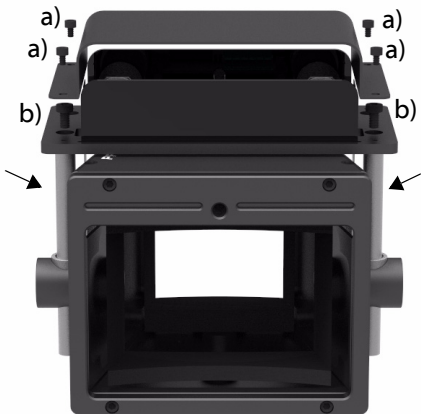

Fig 4

STEP 4

Flip the **lens unit** back upright. Remove the motor cover of motor box by releasing the four cap screws using the **L-wrench 3 mm (Fig 4-a)**.

After this, using the **L-wrench, 4 mm**, remove the both **shipping rails**, shown with arrows in a Fig 4, by releasing the each **cap screw, M6 x 10**, locating under the motor cover (**Fig 4-b**).

STEP 5

Now, refer to **Fig 5**, attach the four **stand rails** to **stand plate** with **cap screws, M6 x 10**. Make sure the 12 mm Ø rails and 15 mm Ø rails are placed to the correct spots on a **stand plate**. Tighten screws in the **slots** of **stand plate** securely using the **L-wrench, 4 mm**.

in this step also insert the four **slide locks** to their places on a **stand rails** 15 mm Ø. Make sure the each lock pair is in a same plane on a rail. The final positions to the locks will be defined by your setup, and thus they may need to be repositioned later, when setting up the system.

NOTE: Some setups may need an extra height to the slide travel. In order to extend the travel, use the **rail extenders** of main rails (**Fig 5**). The set of extension rails increases the slide travel for 4.5 cm. The each extension rail is screwed securely into the main rail, after which it is working as a single, longer **stand rail**.



Fig 5



Fig 6

STEP 6

Now very carefully set the **lens unit** onto the **stand plate** with **stand rails** as presented in **Fig 6**, so that 12 mm Ø rails go through the linear bearings of lens drums on sides. Refer to **Fig 6**, turn the upper **slide locks** aside from the lens when inserting the lens. Connect the **lens unit** to four rails with **cap screws, M6 x 10 (Fig 6-a)**. Tighten the screws securely using the **L-wrench, 4 mm**

Finally attach the motor cover back with four cap screws using the **L-wrench 3 mm (Fig 6-b)**.

Your lens is now ready for setting up !

Setting up the system:

Fig 7

STEP 7

Make sure the projector is turned on. It is helpful to have a picture that fills the entire panel of 16:9 projector. With a 2.40:1 source material the vertical expand is good to be performed to the picture at this step (**Fig 7**).

Now carefully adjust the focus of projector. Also make sure the image is symmetrically in the center of the 2.40:1 screen.

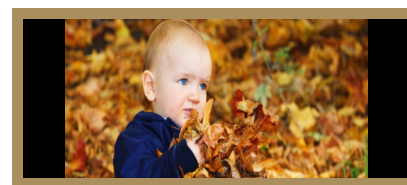
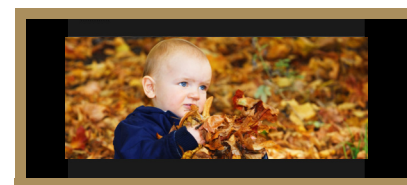
STEP 8

Make sure the power plug has been connected to the socket of lens motor box, locating on the rear IR window.

Carefully position the lens with a lift stand in front of the projector, with the small opening closest to the projector lens and the large opening pointing towards the screen.

Now press and hold the 'in' button of remote controller until the lens has reached the level of projector's optics. Make sure the entire beam fits centered within the two lenses (**Fig 8**). Lower, raise, turn and tilt the lens until the desired height and angle is reached, and the picture is symmetrically in the center of the 2.40:1 screen.

Now move the lower pair of **slide locks** into the contact with stand drums, exactly as illustrated in **Fig 8**. Make sure the locks are exactly at the same plane.

NOTE: The optimum symmetry for the projected picture can only be found by tilting the lens to the direction of the beam

**Fig 8****STEP 9**

For the presentation of native 16:9 material press and hold the 'out' button of remote controller until the lens has completely moved aside from the beam (**Fig 9**). Make sure the lens do not hit the plate of motor box. If needed use the rail extenders to get more travel to the lens.

Now move the upper pair of **slide locks** into the contact with stand drums, exactly as illustrated in **Fig 9**. Again, make sure they are in a same level with each other. Finally, after the correct position is found, tighten the set screws of all four **slide locks** by using **L-wrench, 4mm**.

**Fig 9****STEP 10**

Next adjust the lens focus. By using the **L-wrench 5 mm**, turn the cap screw in front (**Fig 10**) to either direction until the 2.40:1 picture gets focused. It is helpful to use a test grid to monitor when the horizontal and vertical lines in a picture become in focus simultaneously.

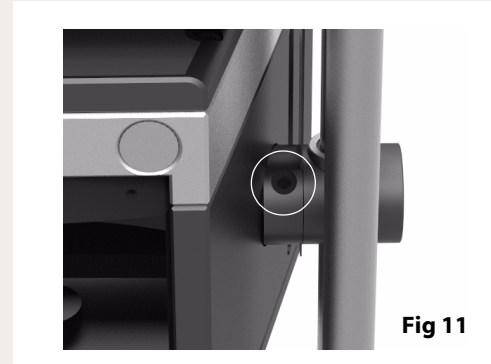
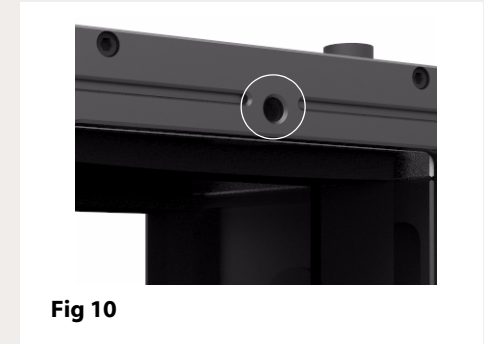
**Fig 11****Fig 10****STEP 11**

In case the friction based tilt adjusting mechanism (**Fig 11**) become too loose, it is possible to get it tightened with the set screws of stand drums on both sides of lens. Use the **L-wrench, 4 mm** for tightening the screws.

SPECIAL NOTES:

- Use the lens only in an upright position. The lift system does **NOT** work, and may **get damaged**, if the lens is used upside down.
- If, however, the lens is flipped upside down e.g. for the installation of rail extenders, make sure the lens has been driven up, and is in contact with the motor plate of slide.
- Save the shipping rails, and use them in case of re-shipment of the lens



You're done. Enjoy your new 2.40:1 picture!

Maintenance:

Your Prismasonic lens was designed to require very minimal cleaning. It is best to only wipe the lens housing with a clean, damp, soft cloth when needed.

Cleaning the optics:

Only use optically safe lens cleaning solutions and a clean, lint-free cloth certified for cleaning of lens materials. In order to clean the optics from both sides, the bottom plate can be temporarily removed.